

Polarizing LED ring light

ELE-1975

HIGHLIGHTS

- Intensity adjustable LED ring light
- Removable polarizer/analyzer
- 5 Degree read-out
- Designed to reduce unwanted glare and reflections
- Highlights details and structures in the samples
- Control over polarization direction
- Accepts 35 to 62 mm stereo heads



● ELE-1975



TECHNICAL SPECIFICATIONS

LED	High power LEDs, 16 pcs
Color temperature	6500-7500 K, white
Light intensity	0% - 100% adjustable
Light power	≥ 44000 lux @ 100 mm
Environment temperature & Humidity	0 - 40° Celsius / 20 - 80% RH
LED life span L70	Typical 30,000 hours (according to lumen depreciation L70 IEC 62722-2-1)
Working distance	40 - 120 mm
Power supply	100 - 240 Vac / 24 V dc
Mounting	Accepts 35 - 62 mm stereo heads
Weight (g)	350
Casing	Black oxide aluminum

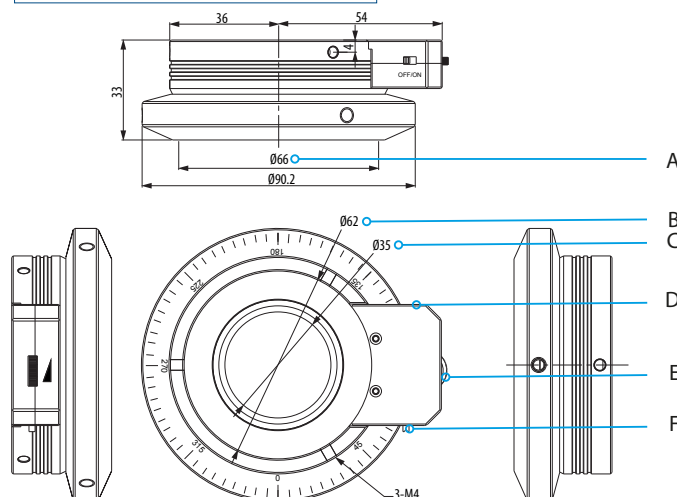

- A. Emitting surface
- B. Fitting diameter: depth 10
- C. Emitting hole diameter
- D. Power input
- E. Light intensity control
- F. ON/OFF switch

BENEFITS POLARIZING LED RING LIGHT:

The polarized ring light minimizes unwanted glare and reflections from shiny or reflective surfaces, such as glass or metal. By controlling the polarization direction, you can effectively eliminate or significantly reduce these distracting elements, allowing for clearer visualization of the specimen. This helps to highlight specific details and structures in the sample, making them more visible and easier to observe

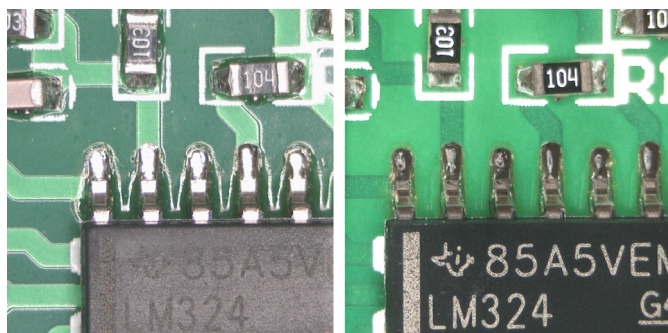

without polarized light

with polarized light



www.euromex.com